



TECHNICAL SPECIFICATIONS

MODEL: B5T210-150SC

210S, 5 TINE, 1 1/2 YD³, GRAPPLE, BN24705

1 1/2 YD ³ 5 TINE 210 SERIES GRAPPLE		
Open	104 "	2641.6mm
Capacity	1.50 yd ³	1.15 m ³
Cylinder Bore	3.5 "	89mm
Cylinder Max. Pressure	5000 psi	345 bar
Rotator Max. Pressure	1450 psi	100 bar
Flow (Rotate Circuit)	10 gpm	38 Lpm
Flow (Open/Close Circuit)	50 gpm	189 Lpm
Weight (with rotator)	5840 lb	2649 kg

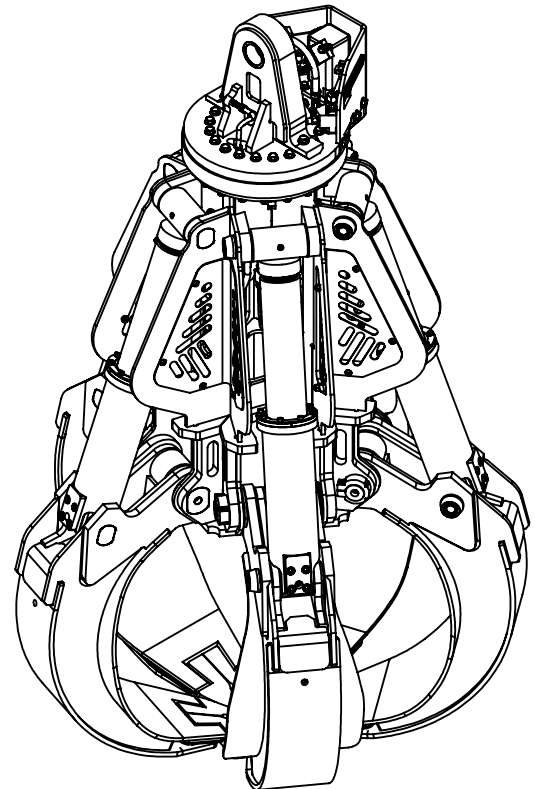
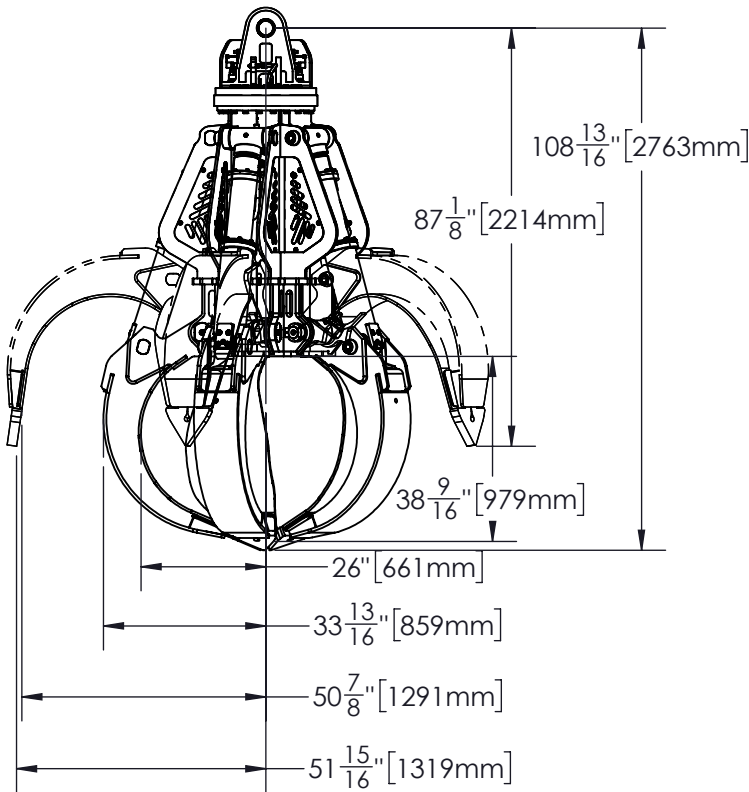
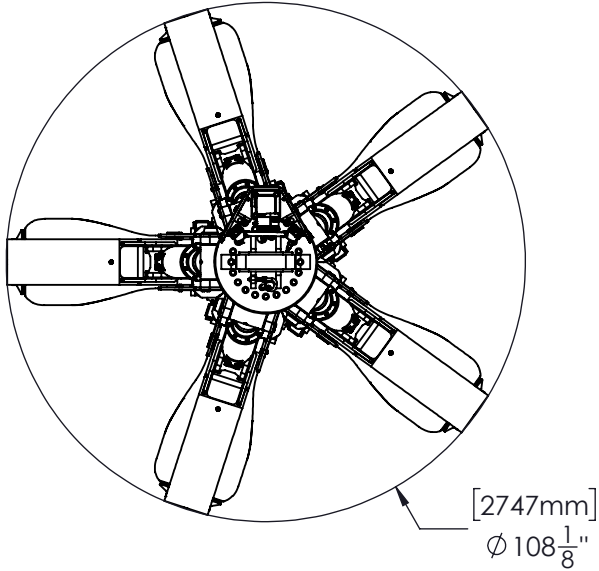

5 Winstar Road
Oro-Medonte, ON L0L 2L0, Canada

info@batemanmanufacturing.com
batemanmanufacturing.com

705-487-5020

