

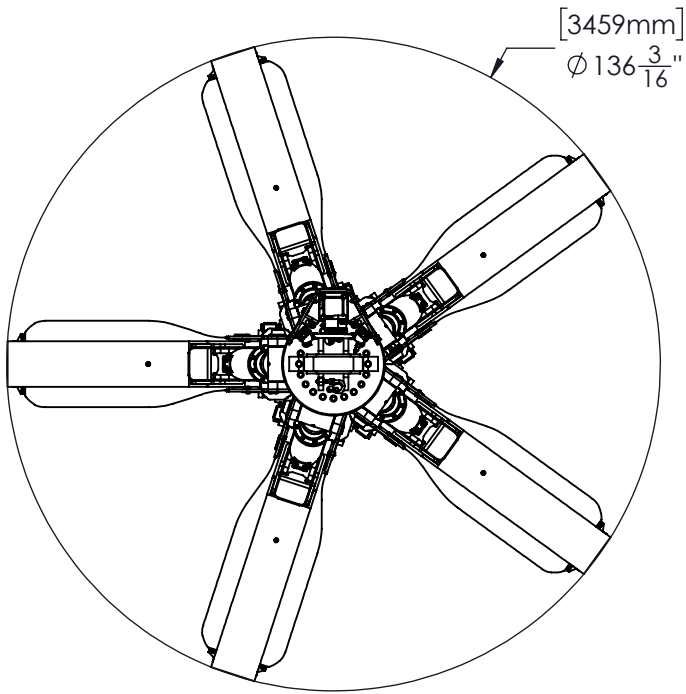

TECHNICAL SPECIFICATIONS

**MODEL: B5T210-250SC**

210S, 5 TINE, 2 1/2 YD<sup>3</sup>, GRAPPLE, BN25143



2 1/2 YD<sup>3</sup> 5 TINE 210 SERIES GRAPPLE

Open	132 "	3340.1mm
Capacity	2.50 yd <sup>3</sup>	1.90 m <sup>3</sup>
Cylinder Bore	3.5 "	89mm
Cylinder Max. Pressure	5000 psi	345 bar
Rotator Max. Pressure	1450 psi	100 bar
Flow (Rotate Circuit)	10 gpm	38 Lpm
Flow (Open/Close Circuit)	50 gpm	189 Lpm
Weight (with rotator)	6615 lb	3001 kg

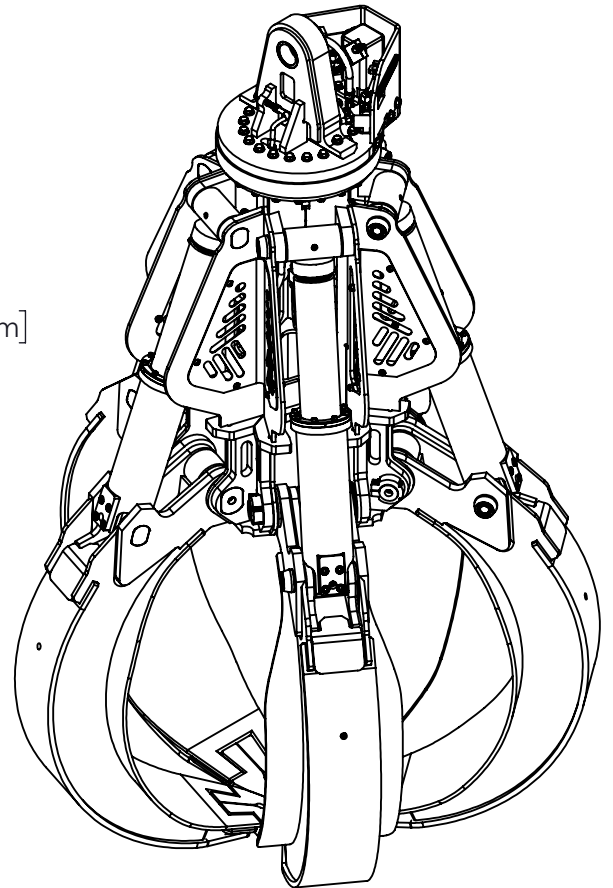
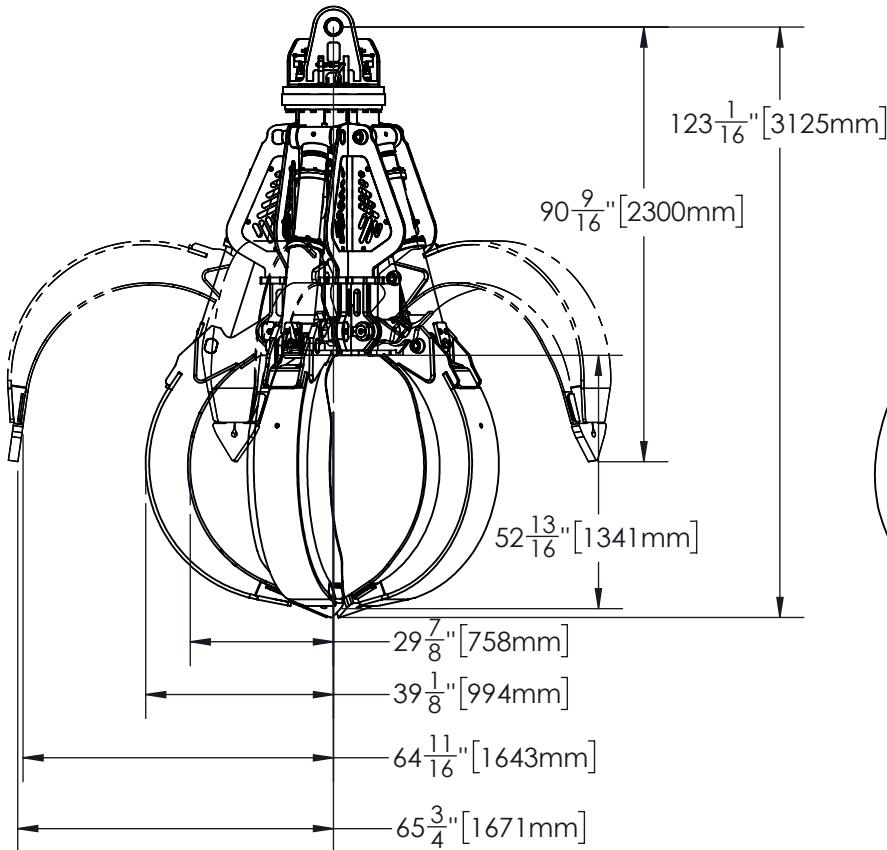

5 Winstar Road  
Oro-Medonte, ON L0L 2L0, Canada

info@batemanmanufacturing.com  
batemanmanufacturing.com

705-487-5020

