

160 SERIES 4/3 DEMOLITION GRAPPLE

Open	72"	1828.8mm
Cylinder Bore	3 1/2"	89mm
Lock valve on Cylinder	Excluded	
Cylinder Max. Pressure	3000 psi	207 bar
Weight (grapple only)	1700 lb	771 kg

160 SERIES DANGLING ROTATOR

Rotation	Unlimited	
Lifting capacity	74200 lb	33657 kg
Max pressure	1450 psi	10.0 MPa
Torque at max. pressure	18400 lb-in	24947.1 Nm
Rotator flow	10 gpm	38 L/min
Rotation speed	15 rpm	
Weight	530 lb	240 kg

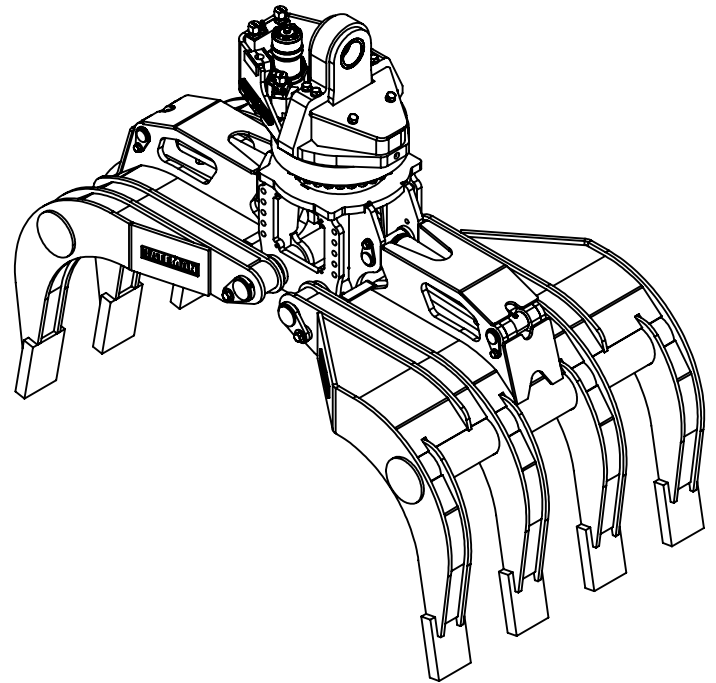
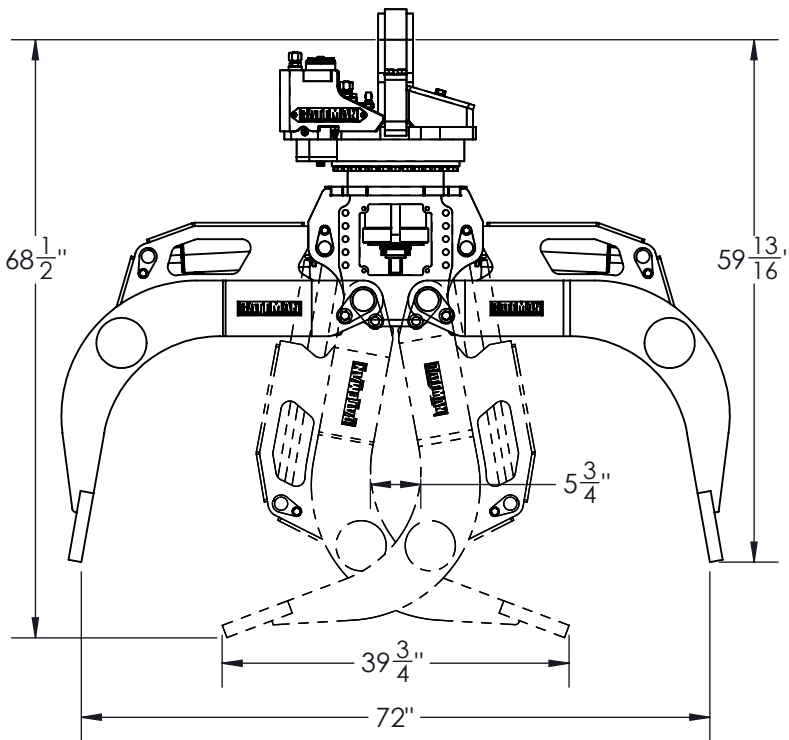

BATEMAN MANUFACTURING
5 WINSTAR ROAD
ORO-MEDONTE, ONTARIO
LOL 2L0, CANADA

WWW.BATEMANMANUFACTURING.COM
MAIL@BATEMANMANUFACTURING.COM
PHONE: (705) 487-5020
FAX: (705) 487-5290

BATEMAN
A GRYB COMPANY