

### 160 SERIES 4/3 WOODRAKE GRAPPLE

Open	68"	1727 mm
Area tip to tip	4.7 ft <sup>2</sup>	0.44 m <sup>2</sup>
Cylinder Bore	3 1/2"	89 mm
Lock valve on Cylinder	Excluded	
Cylinder Max. Pressure	3000 psi	207 bar
Weight (grapple only)	1340 lb	608 kg

### 070 SERIES DANGLING ROTATOR

Rotation	Unlimited	
Lifting capacity	18000 lb	8165 kg
Max pressure	3625 psi	25.0 MPa
Torque at max. pressure	30100 lb-in	40810.2 Nm
Rotator flow	10 gpm	38 L/min
Rotation speed	30 rpm	
Weight	130 lb	59 kg

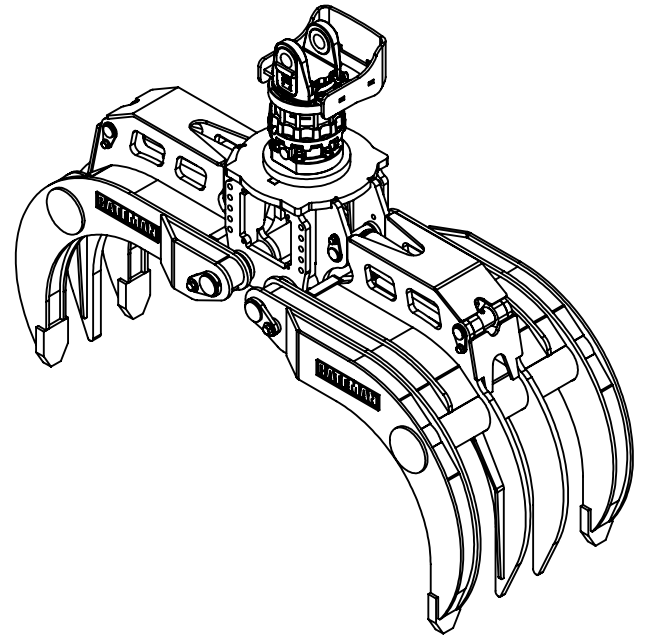
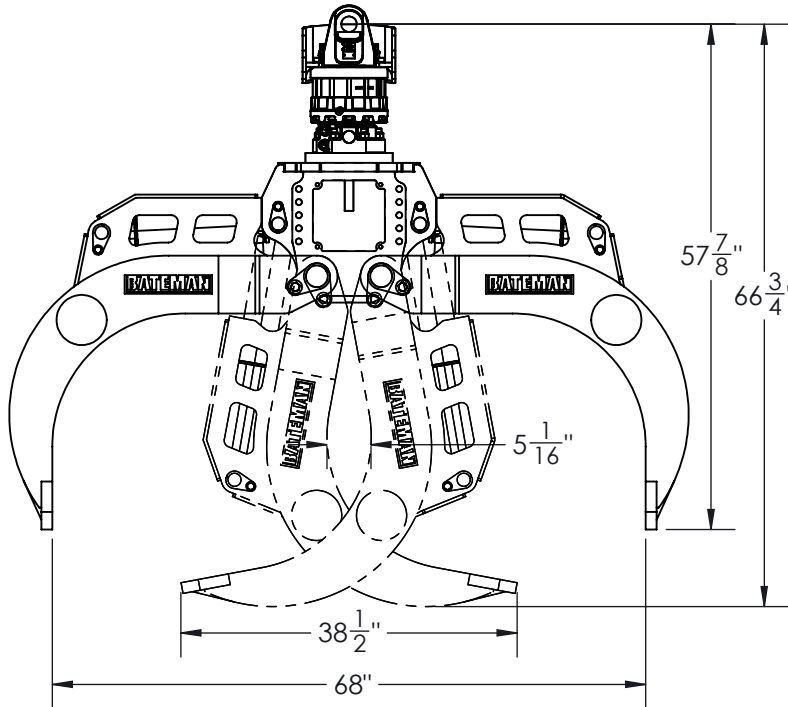

BATEMAN MANUFACTURING  
 5 WINSTAR ROAD  
 ORO-MEDONTE, ONTARIO  
 L0L 2L0, CANADA

WWW.BATEMANMANUFACTURING.COM  
 MAIL@BATEMANMANUFACTURING.COM  
 PHONE: (705) 487-5020  
 FAX: (705) 487-5290



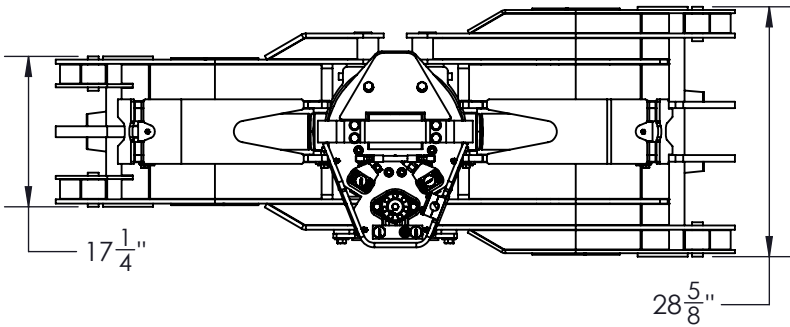

### 160 SERIES 4/3 WOODRAKE GRAPPLE

Open	68"	1727 mm
Area tip to tip	4.7 ft <sup>2</sup>	0.44 m <sup>2</sup>
Cylinder Bore	3 1/2"	89 mm
Lock valve on Cylinder	Excluded	
Cylinder Max. Pressure	3000 psi	207 bar
Weight (grapple only)	1340 lb	608 kg

### 160 SERIES DANGLING ROTATOR

Rotation	Unlimited	
Lifting capacity	74200 lb	33657 kg
Max pressure	1450 psi	10.0 MPa
Torque at max. pressure	18400 lb-in	24947.1 Nm
Rotator flow	10 gpm	38 L/min
Rotation speed	15 rpm	
Weight	530 lb	240 kg

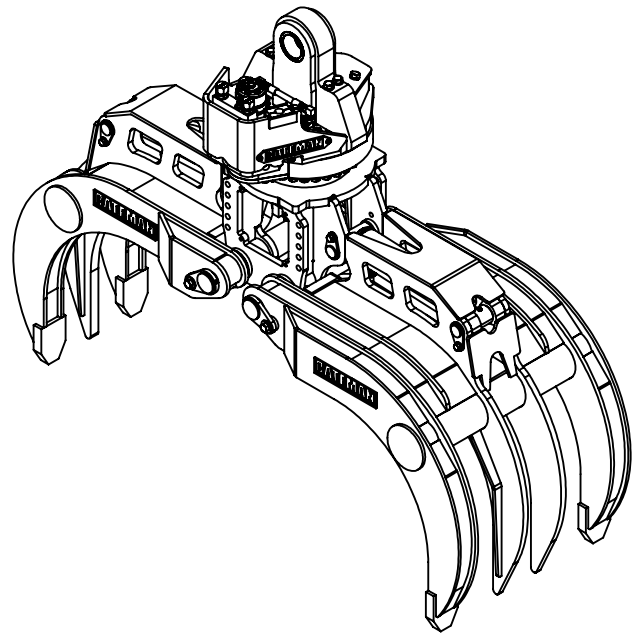
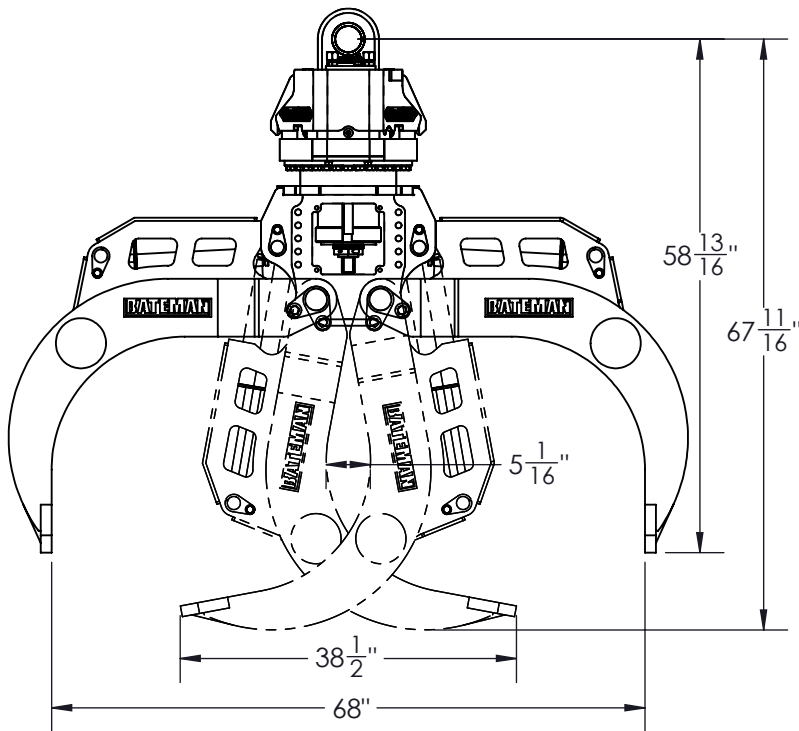

BATEMAN MANUFACTURING  
 5 WINSTAR ROAD  
 ORO-MEDONTE, ONTARIO  
 L0L 2L0, CANADA

WWW.BATEMANMANUFACTURING.COM  
 MAIL@BATEMANMANUFACTURING.COM  
 PHONE: (705) 487-5020  
 FAX: (705) 487-5290



### 160 SERIES 4/3 WOODRAKE GRAPPLE

Open	68"	1727 mm
Area tip to tip	4.7 ft <sup>2</sup>	0.44 m <sup>2</sup>
Cylinder Bore	3 1/2"	89 mm
Lock valve on Cylinder	Excluded	
Cylinder Max. Pressure	3000 psi	207 bar
Weight (grapple only)	1340 lb	608 kg

### 150 SERIES MANIPULATING ROTATOR

Rotation	Unlimited	
Lifting capacity	33720 lb	15295 kg
Max pressure	3625 psi	250 bar
Torque at max. pressure	39828 lb-in	4500.0 Nm
Rotator flow	9 gpm	34 L/min
Rotation speed	25 rpm	
Weight	367 lb	167 kg

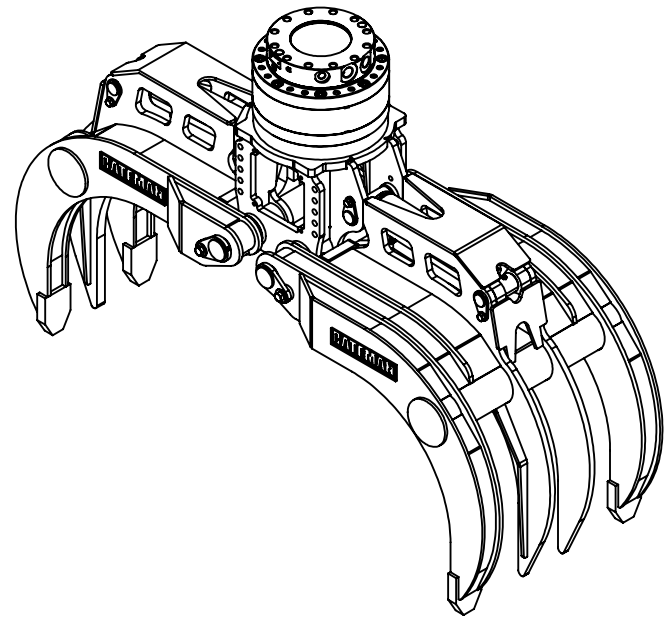
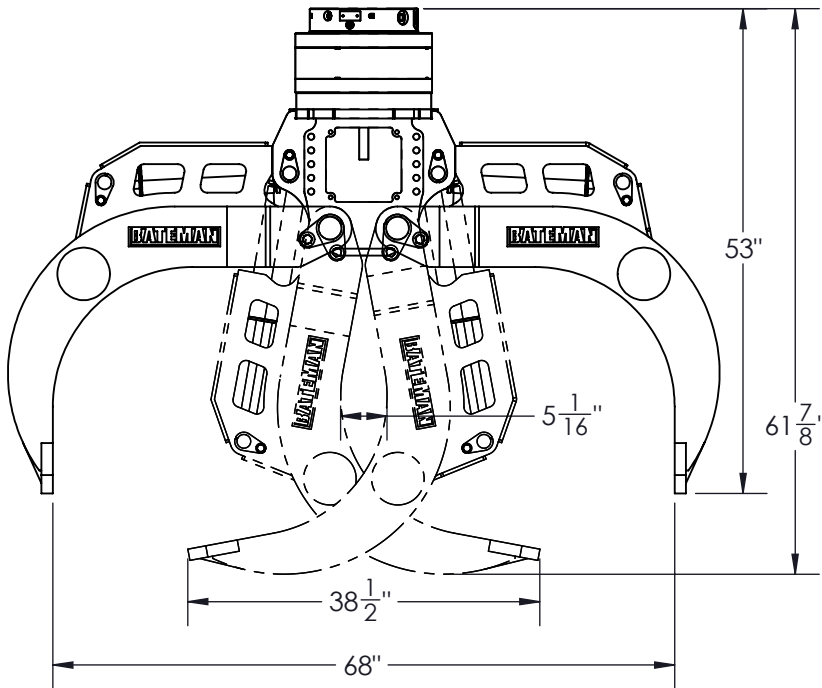
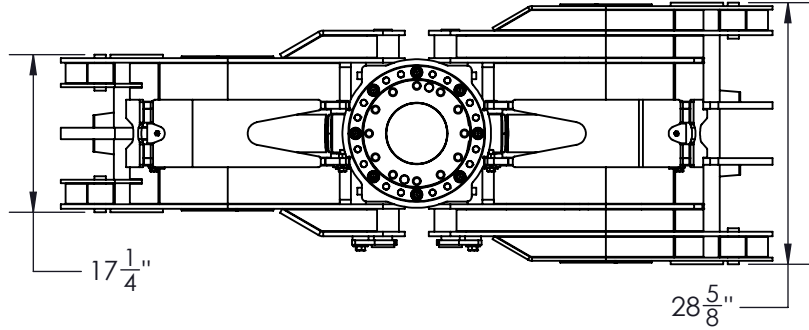

BATEMAN MANUFACTURING  
 5 WINSTAR ROAD  
 ORO-MEDONTE, ONTARIO  
 L0L 2L0, CANADA

WWW.BATEMANMANUFACTURING.COM  
 MAIL@BATEMANMANUFACTURING.COM  
 PHONE: (705) 487-5020  
 FAX: (705) 487-5290



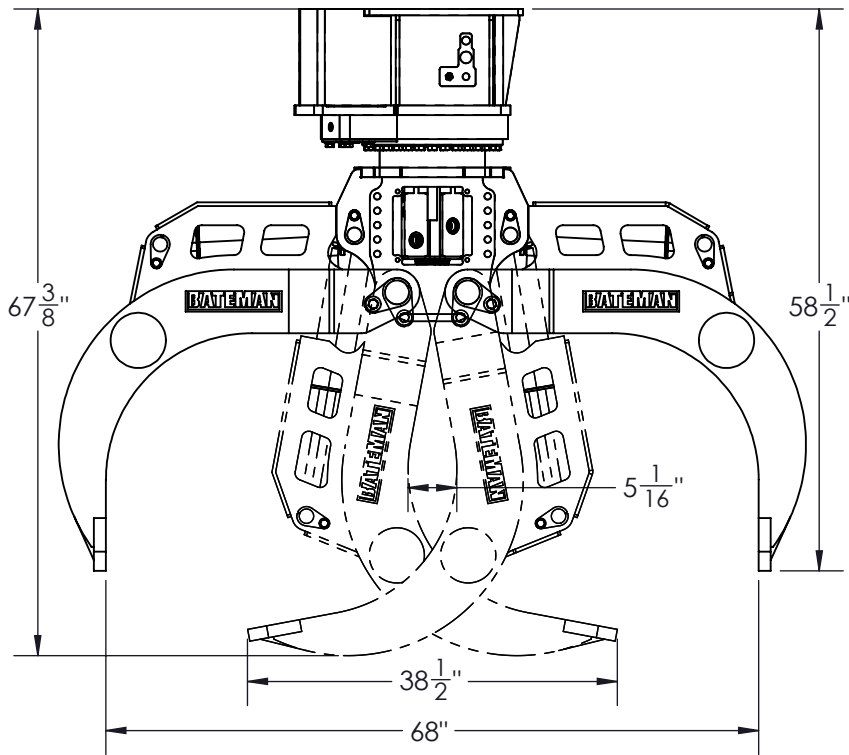
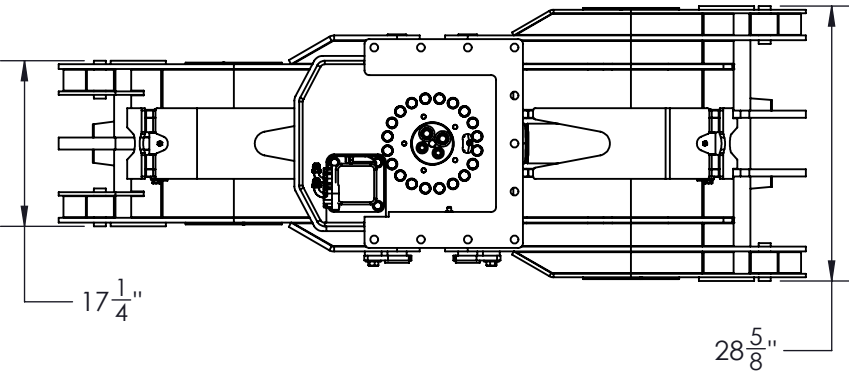

#### 160 SERIES 4/3 WOODRAKE GRAPPLE

Open	68"	1727 mm
Area tip to tip	4.7 ft <sup>2</sup>	0.44 m <sup>2</sup>
Cylinder Bore	3 1/2"	89 mm
Lock valve on Cylinder	Excluded	
Cylinder Max. Pressure	3000 psi	207 bar
Weight (grapple only)	1340 lb	608 kg

#### 160 SERIES MANIPULATING ROTATOR

Rotation	Unlimited	
Lifting capacity	74200 lb	33657 kg
Max pressure	3000 psi	207 bar
Torque at max. pressure	32428 lb-in	3663.9 Nm
Rotator flow	10 gpm	38 L/min
Rotation speed	15 rpm	
Weight	500 lb	227 kg

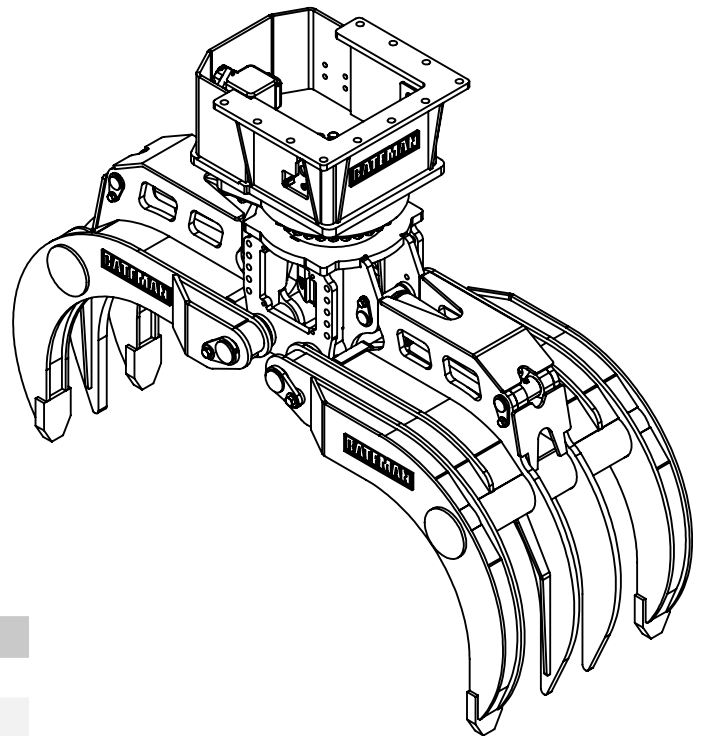

#### 555S GRAPPLE SAW OPTION

Motor size	0.61/1.16 in <sup>3</sup>	10/19 cc
Required pressure	3500 psi	241 bar
Required flow	30/42 gpm	114/159 Lpm
Saw bar length	35/39 in	889/991 mm
Weight	375 lb	170 kg

BATEMAN MANUFACTURING  
5 WINSTAR ROAD  
ORO-MEDONTE, ONTARIO  
L0L 2L0, CANADA

WWW.BATEMANMANUFACTURING.COM  
MAIL@BATEMANMANUFACTURING.COM  
PHONE: (705) 487-5020  
FAX: (705) 487-5290



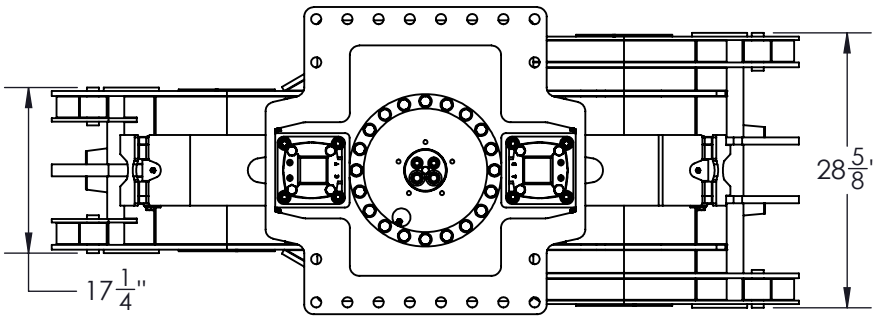

### 160 SERIES 4/3 WOODRAKE GRAPPLE

Open	68"	1727 mm
Area tip to tip	4.7 ft <sup>2</sup>	0.44 m <sup>2</sup>
Cylinder Bore	3 1/2"	89 mm
Lock valve on Cylinder	Excluded	
Cylinder Max. Pressure	3000 psi	207 bar
Weight (grapple only)	1340 lb	608 kg

### 200 SERIES MANIPULATING ROTATOR

Rotation	Unlimited	
Lifting capacity	112,000 lb	50802 kg
Max pressure	3000 psi	207 bar
Max torque	175200 lb-in	19794.9 Nm
Rotator flow	30 gpm	114 L/min
Rotation speed	18 rpm	
Weight	1200 lb	544 kg

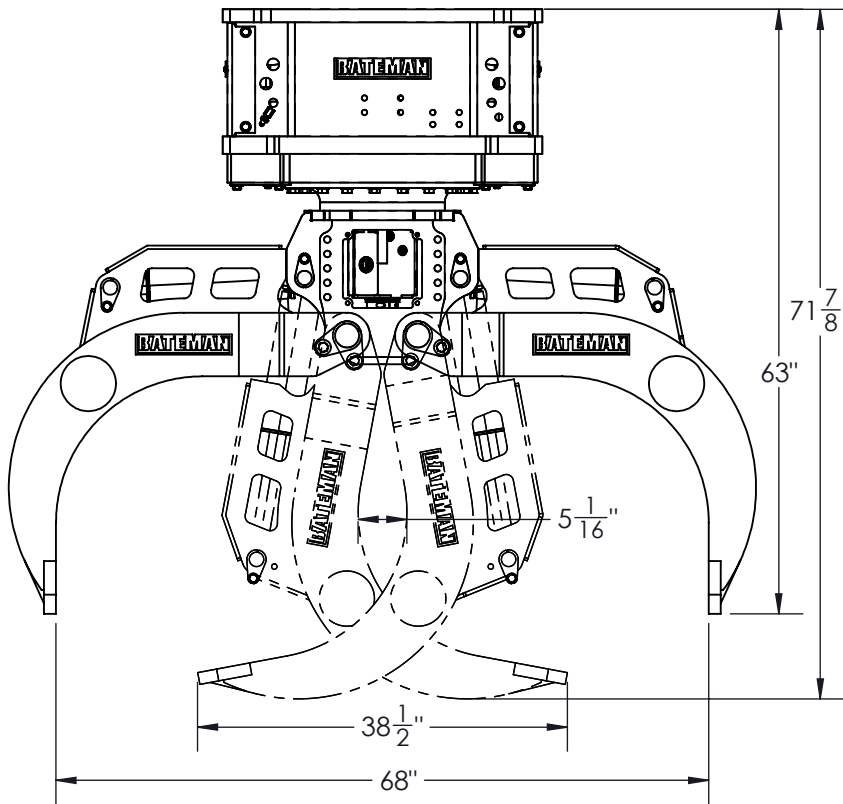

### 555S GRAPPLE SAW OPTION

Motor size	0.61/1.16 in <sup>3</sup>	10/19 cc
Required pressure	3500 psi	241 bar
Required flow	30/42 gpm	114/159 Lpm
Saw bar length	35/39 in	889/991 mm
Weight	375 lb	170 kg

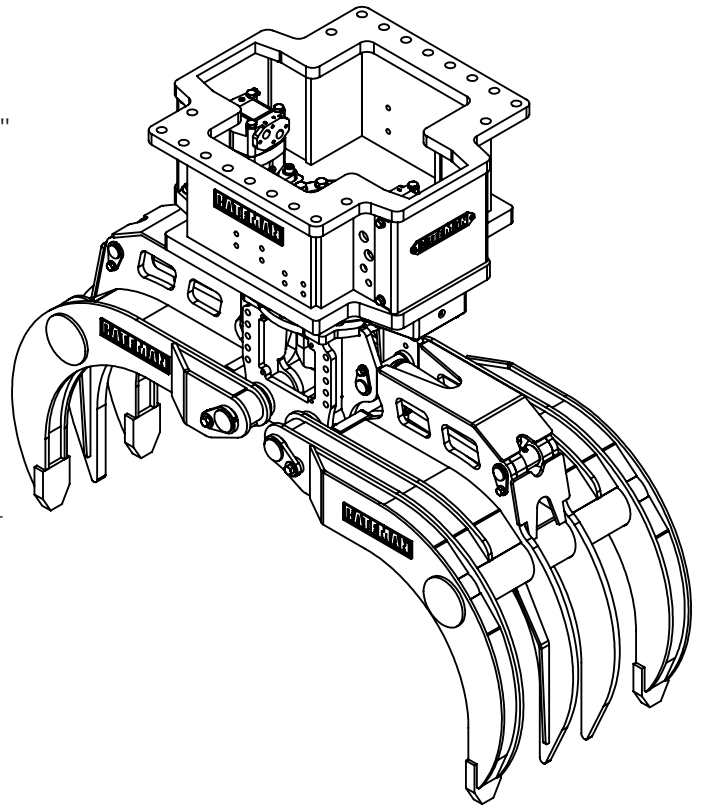

**BATEMAN MANUFACTURING**  
 5 WINSTAR ROAD  
 ORO-MEDONTE, ONTARIO  
 L0L 2L0, CANADA

**WWW.BATEMANMANUFACTURING.COM**  
**MAIL@BATEMANMANUFACTURING.COM**  
**PHONE: (705) 487-5020**  
**FAX: (705) 487-5290**

